

High-Speed, High-Resolution Smart Sensor Solutions

IC-X25B-CL

26MP @ 30 FPS



- 26 Mega Pixels @ 30fps
- Resolution 5120 x 5120
- Monochrom and Bayer Color
- Global Shutter 1 μ sec ~ 10sec
- Optimized Flat Field & DP Correction
- 8-bit Data Output
- 10-Tap Full Configuration Deca-CL
- F- / M42 / M58 / M72 / LM-Mount
- 4 User Areas for Calibration Storage
- Programmable ROI, Exp. & Strobe Delay

Specifications

Sensor	25 Mega Pixel Color (TBD) & Monochrome CMOS Sensor (Global Shutter)
Resolution	5120 x 5120
Pixel Size	4.5µm x 4.5µm
Frame Rate	30 fps at 10 Tap Full Mode, 80MHz Pixel Clock
Video Output	Mono8, BayerRG8
Camera Link Configuration	10 Tap 2ch Camera Link Full Configuration (DECA)
Sensor Size	Diameter 35mm, 23.04mm(H) x 23.04mm(V)
Sensitivity	18.16 DN/nJ/cm ²
S/N Ratio	> 42 dB
Dynamic Range	53 dB
Gamma/Knee	Fixed 0.45 or 256 Point LUT
Shutter Speed	1µsec - 10sec, 1µsec step
Lens Mount	F-Mount, M42, M58, M72, LM(Leica M), Custom OEM
Operating Temperature	Operating 0°C ~ 40°C, Storage 0°C ~ 70°C
Humidity	20% ~ 90% Non-Condensing
External Power Supply Voltage	12 VDC ± 10%, 12W
Dimensions	82mm (L) x 82mm (W) x 83.7mm (H)
Weight	520g (include F-Mount)
Image Control	PRNU, Auto & Man. Defect Pixel Correction
Special Function	Programmable Exposure & Strobe Delay, ROI, 4 user Area for Calibration Storage

* All specifications subject to change without notice.

Connector

Pin No.	Power		
	I/O	Signal Name	
1	DC	+12V	
2	DC	+12V	
3	DC	+12V	
4	GND	GROUND	
5	GND	GROUND	
6	GND	GROUND	

Mating Connector : Female (part#HR10A-7P-6S)

Pin No.	Control		
	I/O	Signal Name	
1	INPUT	TRIGGER +	
2	INPUT	TRIGGER -	
3	GND	GROUND	
4	OUTPUT	STROBE OUTPUT	

Mating Connector : Male (part#HR10A-7P-4P)

Spectral Response

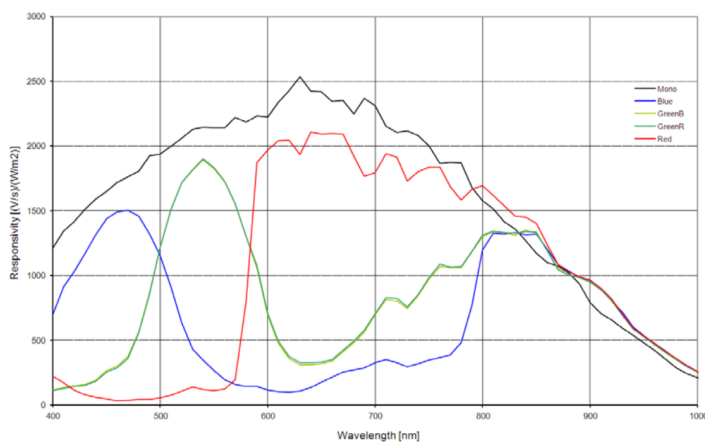

www.isvi-corp.com

Dimensions

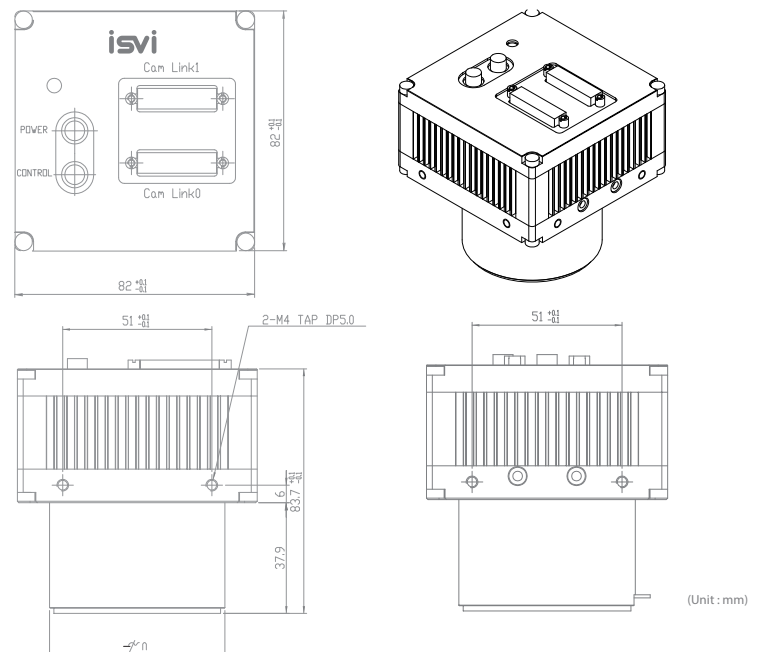

(Unit : mm)

ISVI Korea (Headquarters)
 #103-808 SK Ventum Bldg., 166 Gosan-ro,
 Gunpo-si, Gyenggi-do, 15850, S. Korea
 T +82-31-427-3243 E sales@isvi-corp.com

TECHWAY
 SIGNAL VISION SYSTEM
 info@techway.fr
 +33 (0)1 64 53 37 90

19 Avenue de Norvège
 91140 Villebon sur Yvette
 FRANCE

www.techway.fr

isvi

ISVI-DS-X25BCL-v2.1-Dec17